

SL-1 GREASE INJECTOR

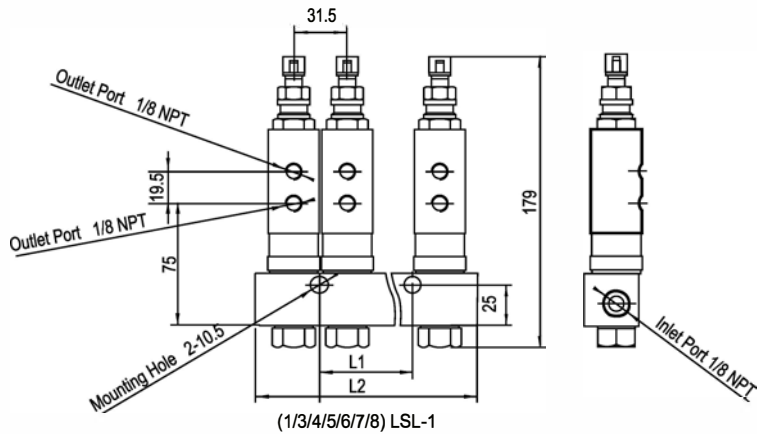

Features

- Design for single-line high pressure automatic lubrication system.
- Suitable for dispensing grease compatible up to NLGI #2.
- Grease output is adjustable.
- Indicator pin allows convenient visual inspection of injector operation.
- Each injector can be removed easily for inspection or replacement.
- High quality single zinc-nickel surface treatment to achieve high corrosion resistance, to provide full protection in high corrosion environment.

Dimensions

No. of Outlet Port	1	2	3	4	5	6
L1 (mm)	-	-	32	63.5	95	126.5
L2 (mm)	63	77.5	109	140.5	172	203.5

Parameters

Model	Output Volume	Min. Pressure	Max. Pressure	Suggestion Pressure	Reset Pressure	Inlet Port Size	Outlet Port Size	Compatible Grease
	cc/cycle	Bar	Bar	Bar	Bar	Inch	Inch	NLGI
LSL-1	0~1.30	122	242	173	40	1/8 NPT	1/8 NPT	#000~#2

SL-1 GREASE INJECTOR

Manifold Type Injectors

Model	Type	Manifold
860181770-1	Single injector manifold	860112658
860181770-2	Two injector manifold	860111962
860181770-3	Three injector manifold	860111963
860181770-4	Four injector manifold	860111964
860181770-5	Five injector manifold	860111965
860181770-6	Six injector manifold	8601246965

Service Parts

Item No.	Description	Qty.	Part No.
1	Adjusting screw	1	860111623
2	Lock nut	1	860111624
3	Piston stop plug	1	860111450
4	Gasket	2	#
5	Washer	1	#
6	Viton o-ring	1	#*
7	Piston assembly	1	#
8	Fitting assembly	1	860190471
9	Plunger spring	1	#
10	Spring seat	1	#
11	Plunger	1	#
12	Viton packing	1	#*
13	Inlet disc	1	#
14	Viton packing	1	#*
15	Washer	1	#
16	Gasket	1	860131064
17	Adapter bolt	1	860111961
18	Adapter	1	860113216
19	Viton packing	1	#*

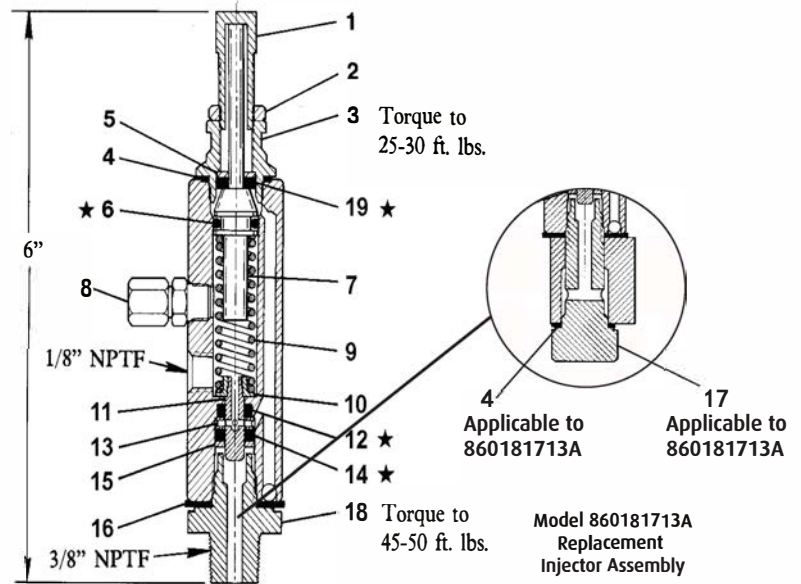

Model 860181713
Single Unit Injector

Included in 8601250158 Repair Kit.

* Included in 8601246000 Soft Parts Kit.