

D200 Grease Metering Device



Grease



2.5MPa



Pressure-relief



NLGI 000~2



Feature

The metering device is reliable and stable, with multiple metering quantities, push-in and screw-type connections, it can be connected to the lubrication tubing flexibly and conveniently.

Order code

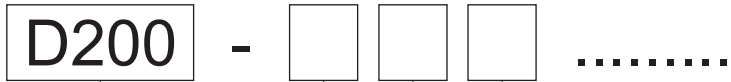

Lubricant metering device

D200 series lubrication distributor

Number of outlets

2 = 2 outlets

...

20 = 20 outlets

First outlet

S03 = 0.03mL/cycle, screw type unit

S05 = 0.05mL/cycle, screw type unit

S10 = 0.10mL/cycle, screw type unit

S20 = 0.20mL/cycle, screw type unit

S30 = 0.30mL/cycle, screw type unit

S50 = 0.50mL/cycle, screw type unit

P03 = 0.03mL/cycle, push-in type unit

P05 = 0.05mL/cycle, push-in type unit

P10 = 0.10mL/cycle, push-in type unit

P20 = 0.20mL/cycle, push-in type unit

P30 = 0.30mL/cycle, push-in type unit

P50 = 0.50mL/cycle, push-in type unit

Second outlet

S03 = 0.03mL/cycle, screw type unit

...

(As in the previous)

...

P50 = 0.50mL/cycle, push-in type unit

Specifications

Model	Outlets	Metering quantity	Inlet	Outlet	A(mm)	B(mm)	Pressure
D300-2	2	0.03mL/cycle 0.05mL/cycle 0.10mL/cycle 0.20mL/cycle 0.30mL/cycle 0.50mL/cycle	M10x1.0 $\Phi 6$	M8x1.0 $\Phi 4$	38	49	14bar to 25bar
D300-3	3				54	65	
D300-4	4				70	81	
D300-5	5				86	97	
D300-6	6				102	113	
D300-7	7				118	129	
D300-8	8				134	145	
D300-9	9				150	161	
D300-10	10				166	177	
D300-11	11				182	193	
D300-12	12				198	209	
D300-13	13				214	225	
D300-14	14				230	241	
D300-15	15				246	257	
D300-16	16				262	273	
D300-17	17				278	289	
D300-18	18				294	305	
D300-19	19				310	321	
D300-20	20				326	337	
D300-22	22				342	353	

Screw Style

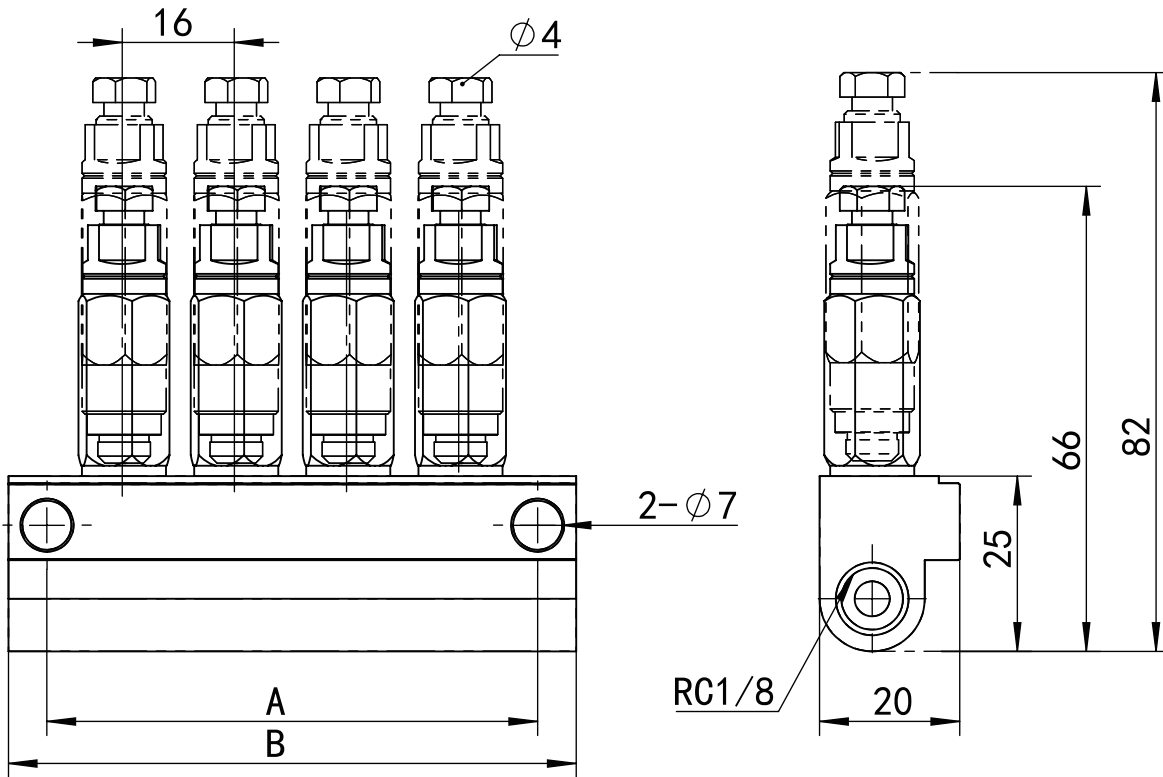

Push-in Style

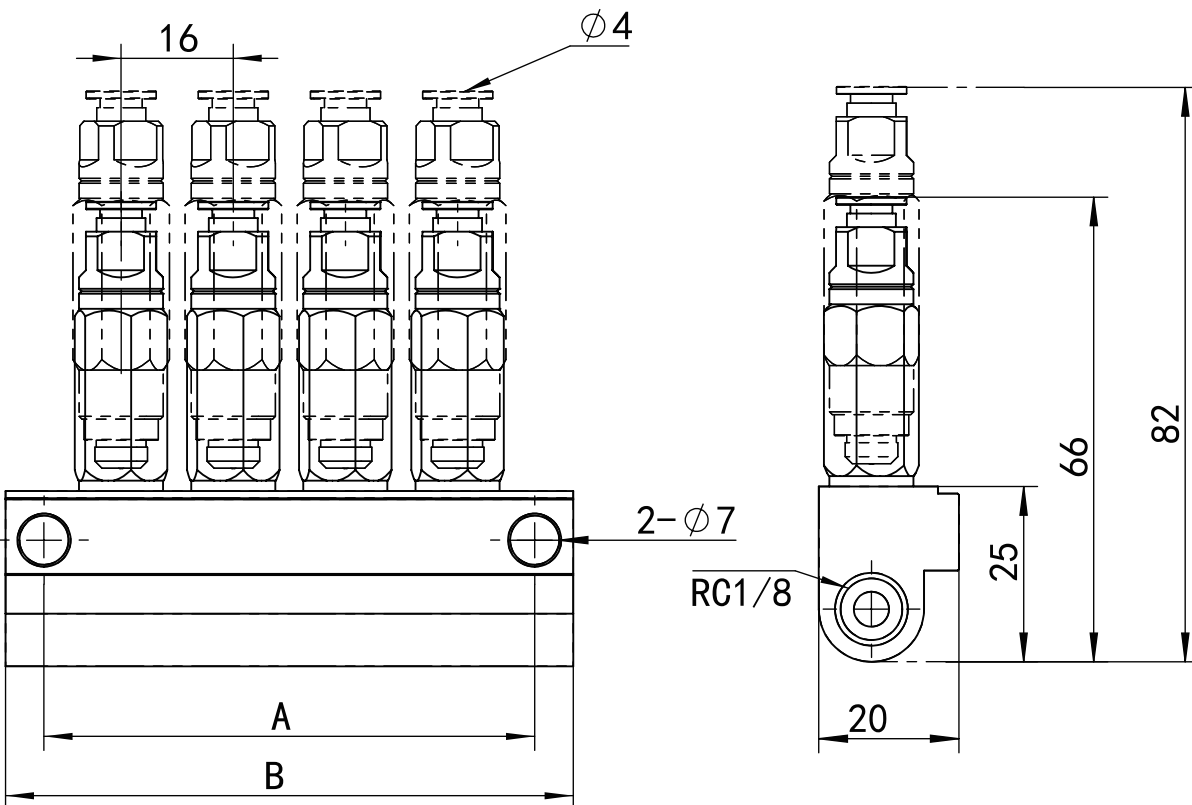

Metering Unit

Model	Metering quantity	L(mm)
S03	0.03mL/cycle	48
S05	0.05mL/cycle	48
S10	0.1mL/cycle	48
S20	0.2mL/cycle	64
S30	0.3mL/cycle	64
S50	0.5mL/cycle	64
P03	0.03mL/cycle	53.5
P05	0.05mL/cycle	53.5
P10	0.1mL/cycle	53.5
P20	0.2mL/cycle	69.5
P30	0.3mL/cycle	69.5
P50	0.5mL/cycle	69.5

Dimensions

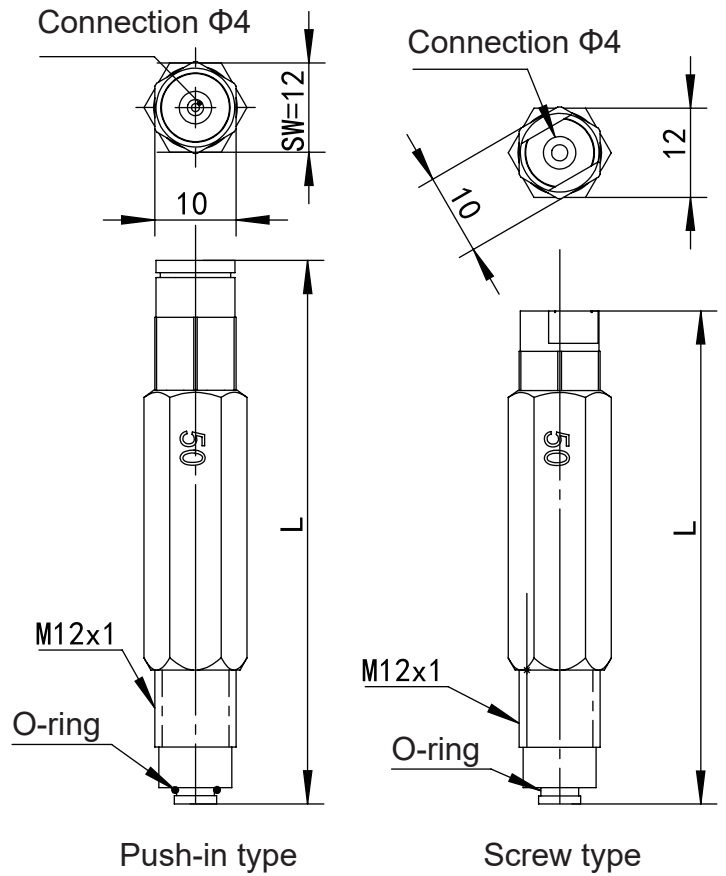

Layout of D200 Metering Device in Lubrication System

